

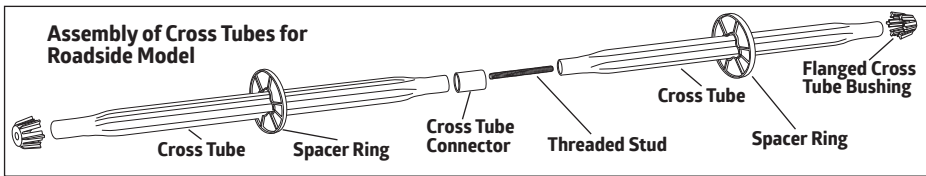

# Uni-Leg® QLA Plus® Sidewalk and Roadside Models

## USER GUIDE

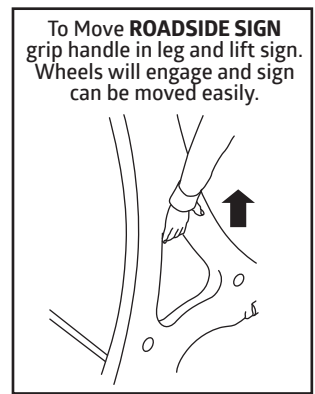
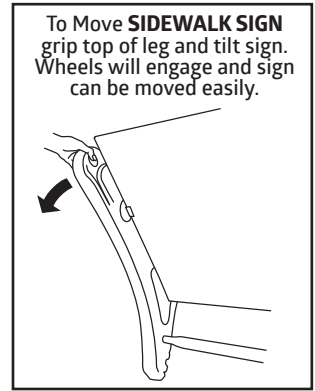
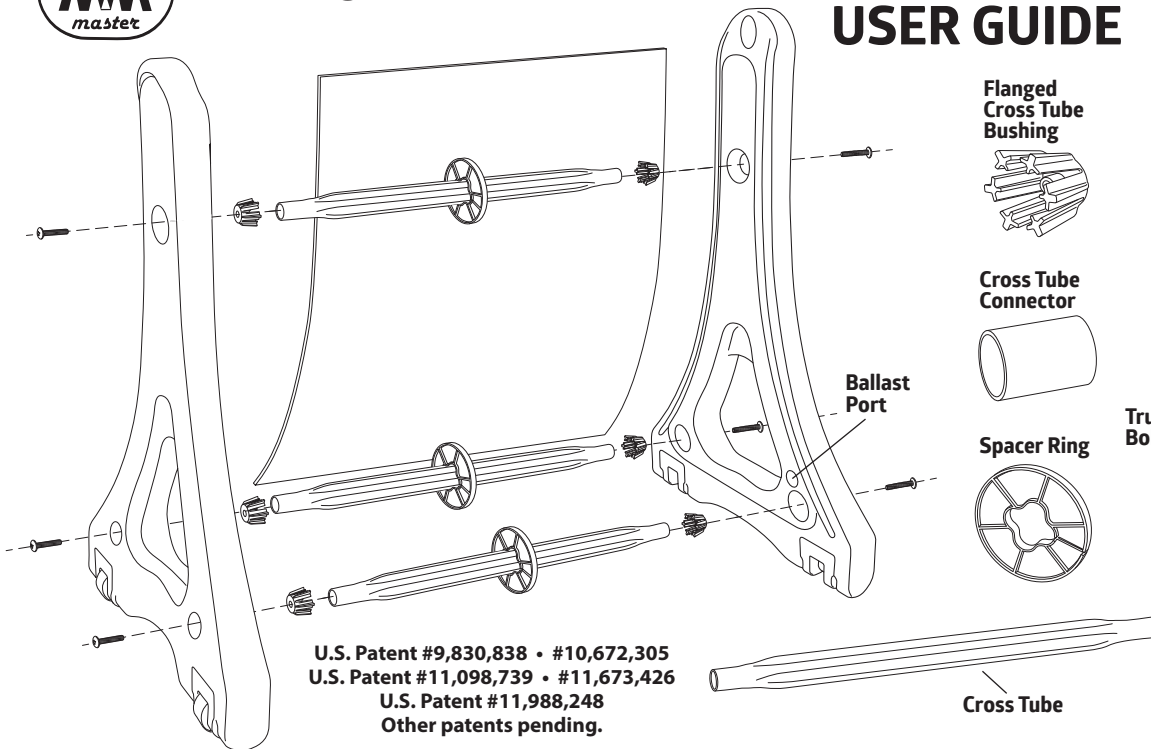

### SIDEWALK MODEL ASSEMBLY

- Slide 1 **Spacer Ring** onto each **Cross Tube** and center using bumps to insure placement.
- On a level surface attach **Cross Tubes** to Sign Uprights using **Flanged Cross Tube Bushings** and **Truss Head Bolts**.
- Put **Flanged Cross Tube Bushing** onto ends of **Cross Tubes** (small end in).
- Slide **Cross Tube** with **Flanged Cross Tube Bushing** into the deep recess of **Sign Leg**.
- Insert **Truss Head Bolt** from outside and tighten.
- Repeat until all 3 **Cross Tubes** are in place in both **Sign Legs**.

### ROADSIDE MODEL ASSEMBLY

- For the **ROADSIDE** model use the **Cross Tube Connector** and **Threaded Stud** to connect 2 **Cross Tubes**.
- Install the **Threaded Stud** into one end of the **Cross Tube**; make sure the red colored thread locker patch on the thread engages the insert in the tube.
- Slide the **Cross Tube Connector** over the end with the **Threaded Stud**. Insert the second **Cross Tube** and tighten firmly. Each double **Cross Tube** should have 2 **Spacer Rings**.
- Repeat to make 3 **Double Cross Tubes**.
- On a level surface attach **Cross Tubes** to **Sign Uprights** using **Flanged Cross Tube Bushings** and **Truss Head Bolts**.
- Put **Flanged Cross Tube Bushing** onto ends of **Cross Tubes** (small end in).
- Slide **Cross Tube** with **Flanged Cross Tube Bushing** into the deep recess of **Sign Leg**.
- Insert **Truss Head Bolt** from outside and tighten.
- Repeat until all 3 **Double Cross Tubes** are in place on both **Sign Legs**.

### Installation of SIDEWALK/ROADSIDE models

For wind resistance up to 30+ MPH add 3-4 quarts of water or sand to each Sign Leg through the **Ballast Port** on the inside of Sign Leg by removing the Cap. Sandbags can also be placed across the bottom oval or the sign can be attached to ground stakes.

• Slide the 4mm corrugated plastic Sign Panel (horizontal flutes) into the Sign Channel on the inside of the Sign Legs; make sure to put sign panels on both sides. The **QLAplus®** accepts 2- 4mm blank corrugated plastic (horizontal flutes) sign

panels, Magic Master® Message Board sign faces, and 'GRIP-IT' snap frame panels that accommodate thinner substrates.

• To move the 'QLA-plus®' Sidewalk model just Grip the top of the **Sign Leg**. Tip the sign to engage the wheels and pull to Roll in, out or about. For the **Roadside** model grip the Hand Hold at the top of the triangular cut out in the leg and lift to Roll in, out or about. The **QLA-plus®** has wheels on both legs

Note: **Roadside QLA** faces have Decor Strip top and bottom.

#### HELPFUL HINTS

- For more interest put a different message on each side of the sign.
- For more variety make reversible sign faces by decorating both sides of the sign face so that the customer can change the message and keep a fresh look.
- Taller sign panels can be used with the top popping out for more impact.
- Combine graphics with letter tracks and changeable letters or headers to create a custom Message Board sign.
- Use 'GRIP-IT' snap frame rails to display thin materials like styrene, waterproof card stock, etc. from 0.010"-0.050" thick.
- Keep message short and simple for maximum impact.
- 'QLA' Quick Load A-frame sidewalk curb/roadside signs are designed for winds up to 30-40 mph. In the event of higher winds bring sign inside or add more ballast.